

Linerless Label Dispenser with Direct Thermal Printer

CTW-D500

for Clear Thermal Wrapping Linerless label

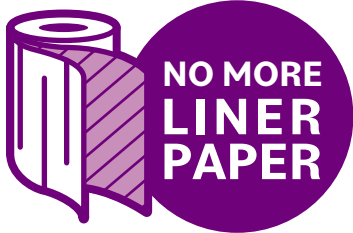

- Print any variable information on the Clear Thermal Wrapping Linerless Label
- Cut and dispense linerless labels to apply on products efficiently
- Ideal for ready meals, baked goods, fruits, vegetables and much more



Primark America Corporation

CTW-D500

for Clear Thermal Wrapping Linerless label

Specifications

Model	CTW-D500-na
Dimensions	760x730x1,450 mm 29.92x28.74x57.08 inch
Weight	about 150kg (330 lb)
Power Supply	AC120V 60Hz
Power Usage	about 500w
Print Resolution	12 dots/mm (approx. 300dpi)
Print Width	165mm (6.5inch) x 2
Print Length	50.08~101.6mm (2~4 inch)

*These specifications are subject to change for improvement without prior notice.

Recommended operating conditions

Temperature	0~35°C(32~95F)
Humidity	30~85%RH

Supported Label

Label Width	240~500mm (approx. 9.5~19.5 inch)
Label Pitch	50.08~101.6mm (2~4 inch)
Adhesive Pattern	12mm x 2 or 3 Lines
Roll Length	200m
Inner Diameter	76mm (approx. 3 inch)

Supported Package

Outside diameter	approx. 254mm~508mm(10~20inch)
------------------	--------------------------------

Dimensions (unit:mm)

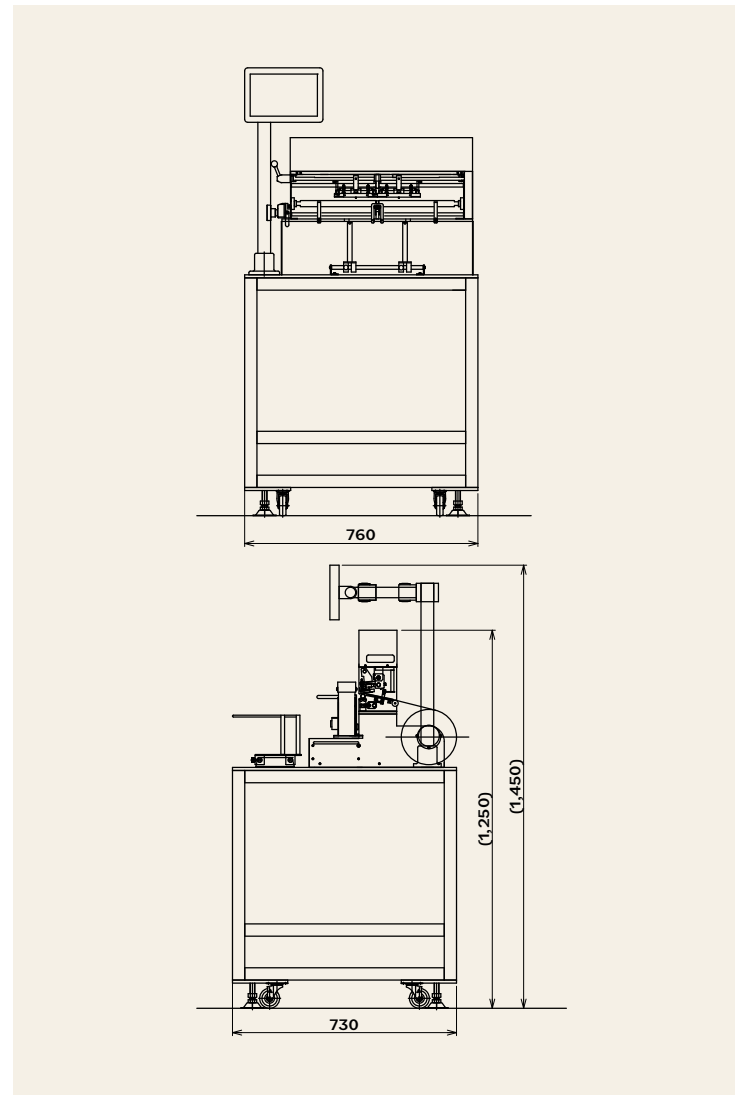

Please visit our show room.

Clear Wrapping Linerless Label LAB.

48-18 Van Dam St, 2FL, Long Island City, NY11101



Primark America Corporation

780 Third Avenue, Suite 2203, New York, NY 10017, USA



WEB SITE